

## Workshop Vernier Caliper 100 Series

### Features

Standard DIN 862

- Standard workshop model with locking screw
- 4-way measurement
- Made of hardened alloyed stainless steel
- Chromed scale with engraved graduations
- Measuring surface is micro-lapped
- Packed in plastic box

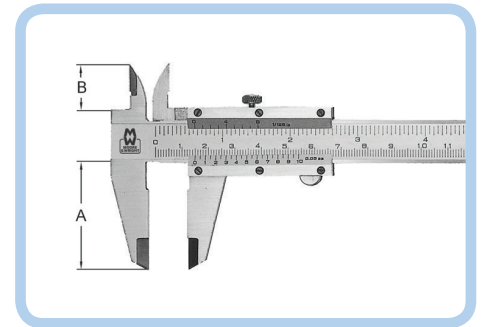
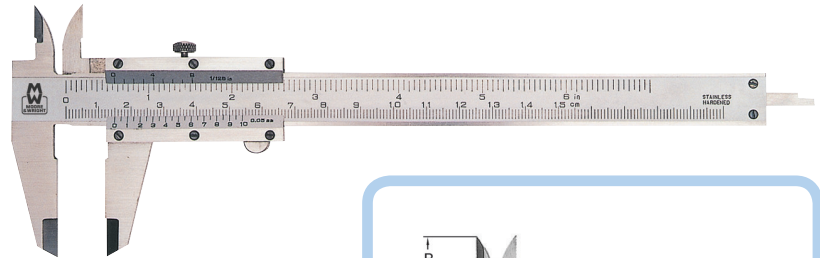

### WORKSHOP VERNIER CALIPER

Code No	Range (mm)	Range (inch)	Resolution (mm)	Resolution (inch)	Dimm – A	Dimm – B
<b>MW100-15B</b>	0-150	0-6	0.05	1/128	40	16
<b>MW100-20B</b>	0-200	0-8	0.05	1/128	50	20
<b>MW100-30B</b>	0-300	0-12	0.05	1/128	55	20
<b>MW100-15BI</b>	0-150	0-6	0.02	0.001	40	16
<b>MW100-20BI</b>	0-200	0-8	0.02	0.001	50	20
<b>MW100-30BI</b>	0-300	0-12	0.02	0.001	55	20